

WattUp® EN3921 Power Amplifier Controller

EN3921 is a power amplifier controller IC that supports biasing, monitoring and dynamic control of the EN3913M GaN power amplifier. The DA4100 transmitter IC, EN3921 controller, and EN3913M GaN Power Amplifier combined charge WattUp-enabled receivers. WattUp receiver technology may be integrated into various devices such as fitness trackers, hearables and wearables, power tools, and other high-power devices.

WATTUP®

WattUp EN3921 Wireless Power Amplifier Controller Block Diagram

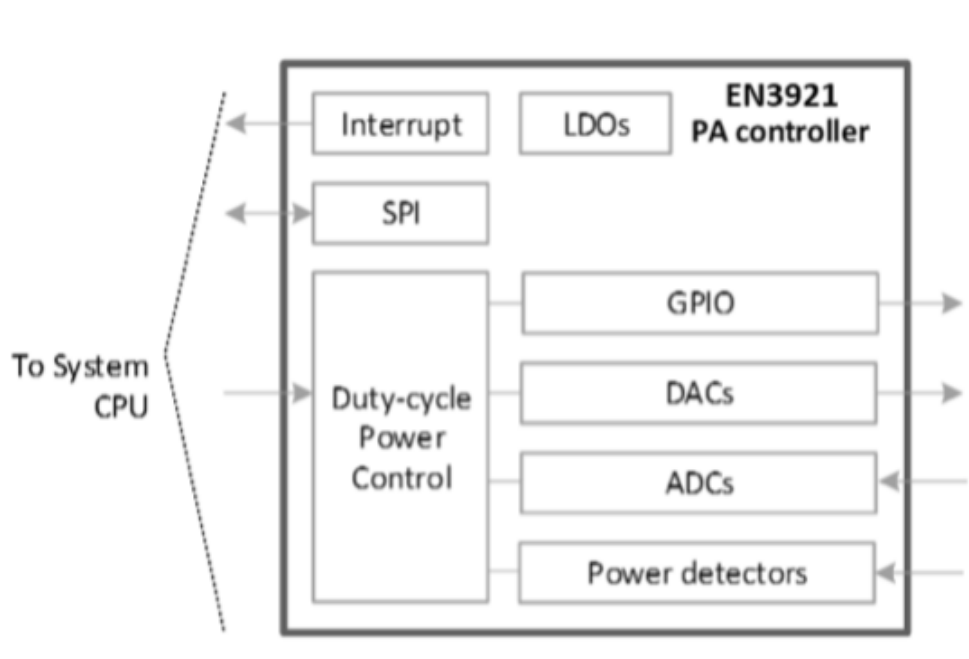



WattUp System Block Diagram

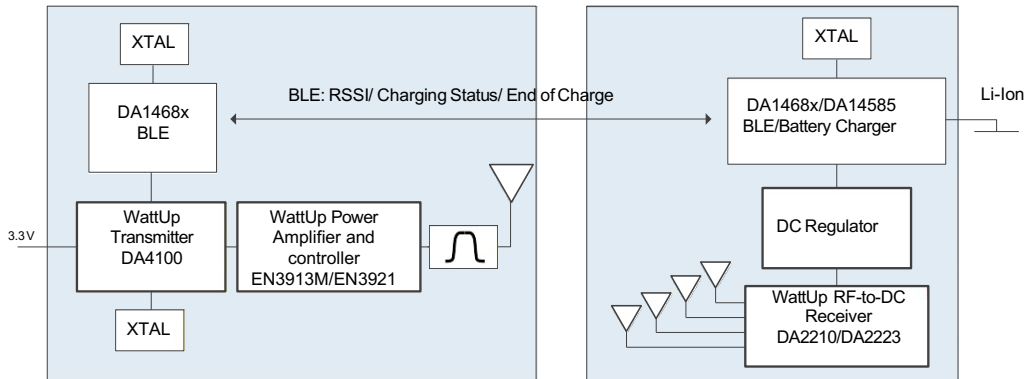

Markets & Applications



Automotive



Consumer



Defense



Health/
Medical



Industrial



Retail

Key Benefits



RF/antenna-based solution



Smaller antenna area than coil-based designs



Improved spatial and orientation freedom



Eliminates connectors and charging contacts



Enables fully sealed waterproof design



This publication is issued to provide outline information only, which unless agreed by Energous Corporation may not be used, applied, or reproduced for any purpose or be regarded as a representation relating to products.

Energous, WattUp, and the Energous and WattUp logos are trademarks of Energous Corporation. All other product or service names are the property of their respective owners. © Copyright 2019 Energous Corporation. All rights reserved.

3590 N. 1st Street Suite 210

San Jose CA 95134

1-408-963-02100

energous.com